



AKRIFORM

Pribox®

**Merchandising Solution
for Pick & Mix**



Pribox®

The New Generation of Pick & Mix Merchandising



Pribox® is a new Pick & Mix solution with several technical features to please customers and facilitate for store and store employees as well as reaching today's high design standards for optimal product display.

Increase Your Sales with Pick & Mix

- Market research indicates an increase in sales of 25–35% within the product category.
- Customers can mix the products themselves allowing the opportunity to pick their favorites and try new products.
- Minimizes the use of resources and energy required to produce cans, boxes, cartons and labels – reducing landfill waste.
- Reduces cost by eliminating product packaging and lowers transportation cost.
- More than half of the consumers who purchase Pick & Mix candy, also purchase packaged candy.
- Creates a friendly, fun, creative shopper retail experience for consumers. Increases impulse purchasing and creates customer loyalty.



Optimizes retail space - offer a large variety of products within a small area. With the Pribox® solution one section with 5 rows can, with dividers, hold up to 45 different kinds of products.

Excellent solution for candy, nuts, grains, coffee, pet food and more.



Innovative Solutions

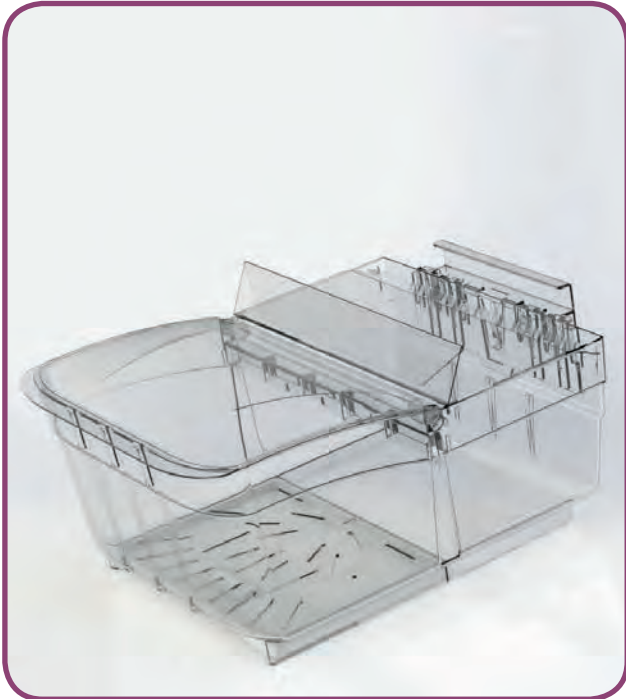

New Modern Design

The low, tilted bin with great volume maximizes the product exposure. The new label holder covers the edges of the shelves, giving the display a clean and unified look.



First in First Out Product Rotation

Refilling from the back lid for maximum product quality and easy maintenance. Dividers allow for easy integration of the bins to create smaller space for lower frequency bulk products.



Stackable and Easy to Assemble

The innovative and patented design presents a new smarter solution for packing, distributing and warehousing.



Self-Closing Lid & Sugar Tray

The slow and quiet, self-closing lid makes it easy for the customer to shop. The lid and sugar tray keeps the products fresh longer.



LED-lighting Brightens the Display

The LED-lighting increases visibility and makes the display an interesting location in the store. The display will attract passersby and become an obvious destination for customers.

SALES BENEFITS



The lower bin makes the display lower as well - even with 5 rows it is easy to pick from the top bins. Endless branding possibilities with color and print options. Fixtures and bins made practical for store use.

STORE BENEFITS



Slide-out feature that allows each individual bin to securely slide out from the display. The top lid stays open during refill. The bin can be individually refilled and requires no heavy lifting.

TECHNICAL BENEFITS

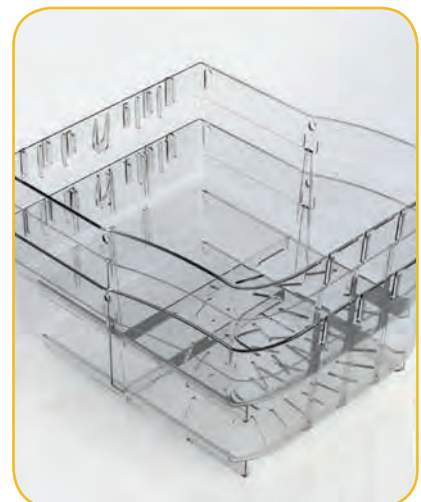

The design makes it possible to transport the bin and fixture un-assembled, allowing for multiple displays to fit per pallet, reducing freight costs.

Fixtures Designed to Fit Your Retail Needs



Accessories such as shelving, top signs, top boxes, lighting, scoops, bag holders, corner sections, shelf fronts and storage drawers provides great flexibility.



Multiple display solutions can be created with the corner sections; against a wall or a free standing island.



The display can be complemented with modules for cups and lids. Trays for bags are standard equipment.

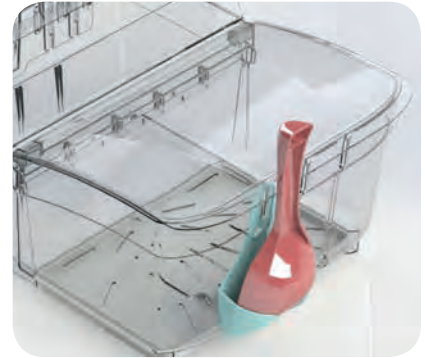

Choose how many scoop holders you want for each bin; none, one or two. Can be made in a number of different colors.



Several different top sign options available. Choose the one that best suit your store. All the signs are designed so that it is easy to change graphic profile and print.



The spillage collector catches any spilled product, minimizing cleaning. The spillage collector also adds additional storage. The bumper protects against shopping carts and industrial cleaning machines.

Measurements

All measurements are in millimeter.

**PATENT
PROTECTED**



*Pribox® is
Normpack Certified
- approved for
containing foodstuff*

Height

Without scoop: 196.3 mm
With scoop: 250.1 mm

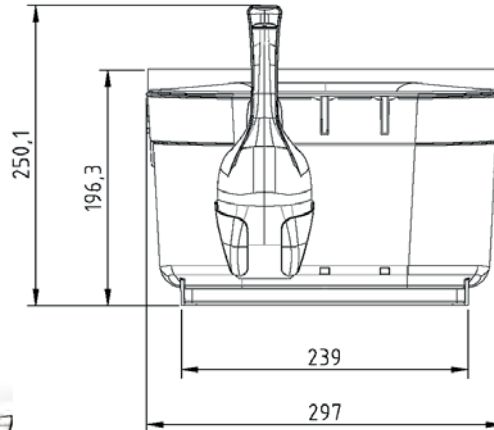

Width

Base: 239 mm
Whole bin: 297 mm

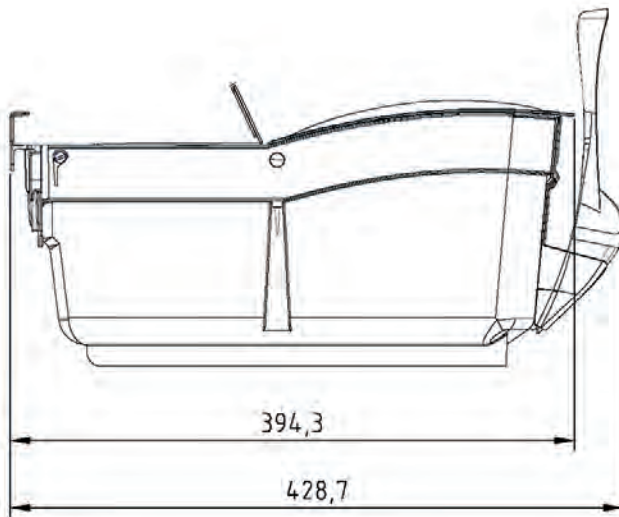

Depth

Without scoop: 394.3 mm
With scoop: 428.7 mm

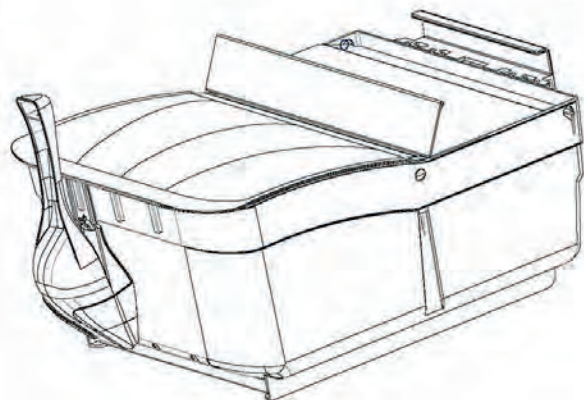

Volume

Whole bin (without dividers): **15 litres**

With 1 divider (2 compartments): Each compartment **7.5 litres**

With 2 dividers (3 compartments): Each compartment **5 litres**

AKRIFORM

Akriform is the developer and manufacturer of the Pribox® Scoop Bin, the Quickbox Scoop Bin and the TurnOflex® Gravity Bin.

Our goal is to offer complete solutions for Pick and Mix products to our world-wide clients through innovative technology. Akriform has produced Pick and Mix solutions for over 30 years and develops and produces new solutions with improvements for both the store and the end consumer. Many solutions are patented and protected.

Akriform is a leading manufacturer of Acrylic, Plexiglas®, products. Our team of designers and engineers develop products and solutions for retail, medical, entertainment, governmental and industrial industries - we believe in the possibilities of plastic.

Akriform's headquarter and manufacturing plant is located in Stockholm, Sweden. An affiliated sales office is located in Texas, USA through Engstrom Trading, LLC.



Akriform Plast AB. Kuskvägen 9, SE-191 62 Sollentuna, Sweden.

Telephone: + 46 8 625 99 00 Email: bulk@akriform.se

www.akriform.com