

PRIBOX® DISPLAY SOLUTION

MERCHANDISING SOLUTION FOR PICK & MIX

AKRIFORM

Pribox®

1

PICK & MIX



Pribox is our latest Pick & Mix solution with several technical features to please customers and facilitate for store and store employees as well as reaching today's high design standards for optimal product display.

2

INCREASE YOUR SALES

- Market research indicates an increase in sales of 25-35% within the product category.
- Customers can mix the products themselves allowing the opportunity to pick their favorites and try new products.
- Minimizes the use of resources and energy required to produce cans, boxes, cartons and labels - reducing landfill waste.
- Reduces cost by eliminating product packaging and lowers transportation cost.
- More than half of the consumers who purchase Pick & Mix candy, also purchase packaged candy.
- Creates a friendly, fun, creative shopper retail experience for customers. Increases impulse purchasing and creates customer loyalty.

Optimizes retail space - offer a large variety of products within a small area. With the Pribox® solution one section with 5 rows can, with dividers, hold up to 45 different kinds of products.



Excellent solution for candy,
nuts, coffee, pet food and
more.

INNOVATIVE SOLUTIONS



NEW MODERN DESIGN

The low, tilted bin with great volume maximizes the product exposure. The new label holder covers the edges of the shelves, giving the display a clean and unified look.

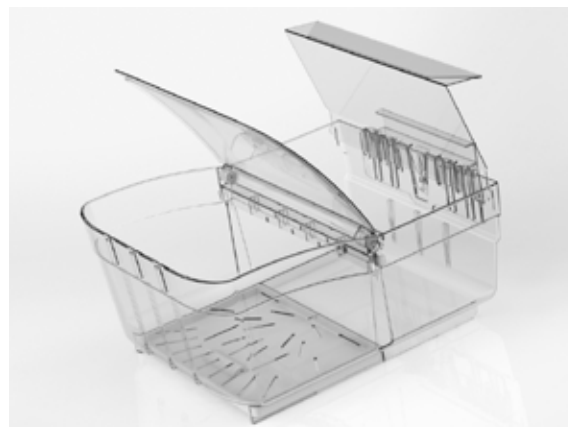

PRODUCT ROTATION

Refilling from the back lid for maximum product rotation and easy maintenance. The slow and quite self-closing pick lid makes it easy for the customer to shop.

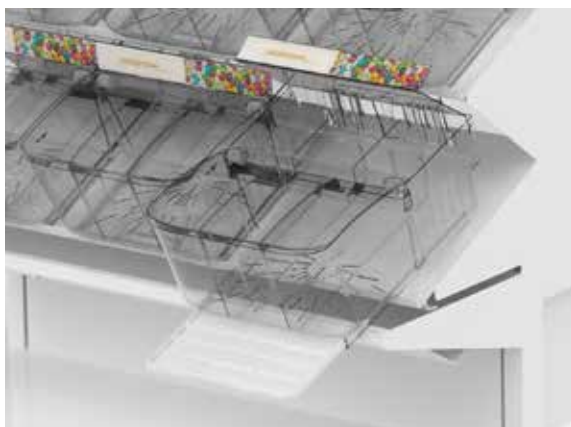

SUGAR TRAY

The compartmentalized sugar tray keep the products fresh longer. With the back hook each bin securely slides out from the display for easy refilling.



NEW

NEW - PRIBOX® SMALL 150

Pribox® Small 150 is half the width of our regular Pribox® bin, 150 mm compared to 300 mm. The two different sizes can easily be combined in the Pribox® racks.

BENEFITS



SALE BENEFITS

The low bin makes the display lower as well - even with 5 rows it is easy to pick from the top bins.

Endless branding possibilities with color and print options. Fixtures and bins made practical for store use.

STORE BENEFITS

Slide-out feature that allows each individual bin to securely slide out from the display. The top lid stays open during refill. The bin can be individually refilled and requires no heavy lifting.

The sloping shelves provide better product exposure.



TECHNICAL BENEFITS

The innovative and patented design makes it possible to transport the bin and fixture unassembled, allowing for multiple displays to fit per pallet, reducing freight and warehouse costs.

The bin is easy to mount, clean and replace spare parts on.

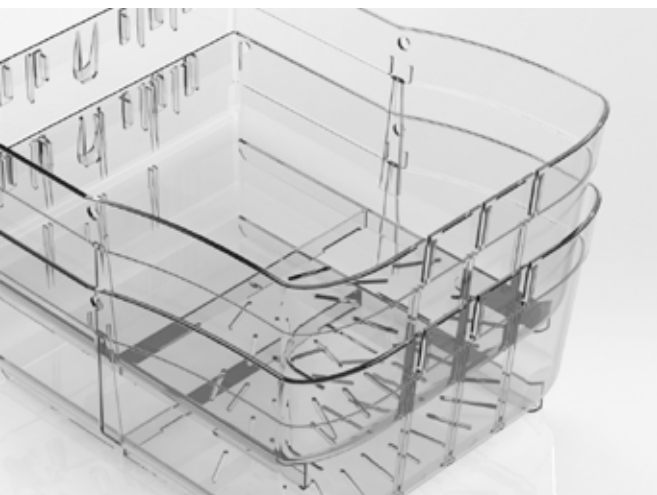

FIXTURES TO FIT YOUR NEEDS

Accessories such as shelving, top signs, top boxes, lighting, scoops, bag holders, corner sections, shelf fronts and storage drawers provides great flexibility.



Multiple display solutions can be created with the 1/4 corner sections; against a wall or a free-standing island.

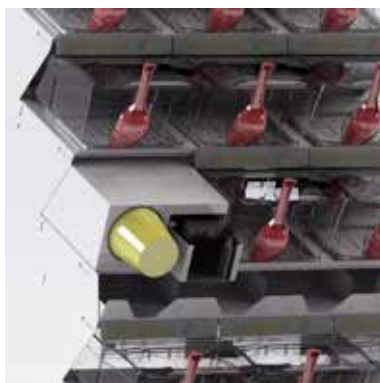

The display can be complemented with modules for cups and lids. Trays for bags are standard equipment.

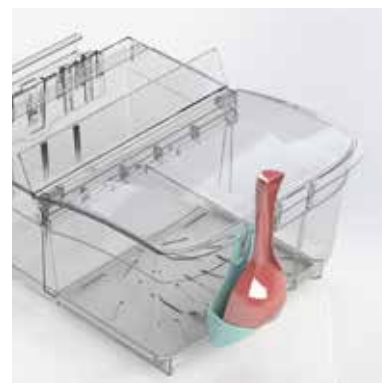

Choose how many scoop holders you want for each bin; none, one or two (with or without tethers). Can be made in a number of different colors.



Several top sign options available. Choose the one that best suit your store. All the signs are designed so that it is easy to change graphic profile and print.



The spillage collector catches any spilled product, minimizing cleaning. It also adds additional storage. The bumper protects against shopping carts and industrial cleaning machines.



The LED-lighting increases visibility. It lids up both label holders and products which makes the display an interesting location in the store. The display will attract passers-by.

MEASUREMENTS

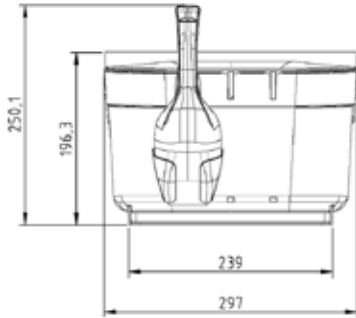

Height

Without scoop: 196.3 mm

With scoop: 250.1 mm

Width

Base: 239 mm

Whole bin: 297 mm

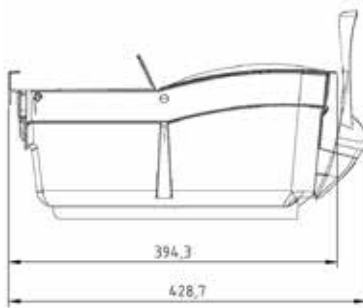

Depth

Without scoop: 394.3 mm

With scoop: 428.7 mm

Weight

1,46 kg

Volume

Whole bin (without dividers): 15 liters

With 1 divider (2 compartments): 7.5 liters/each

With 2 dividers (3 compartments): 5 liters/each



Label holder: 294x40 mm



NEW Pribox® Small 150

Width: 147.2 mm

Volume: 7 liters

Label holder: 145x40 mm

Pribox® is Normpack Certified - approved for containing foodstuff.



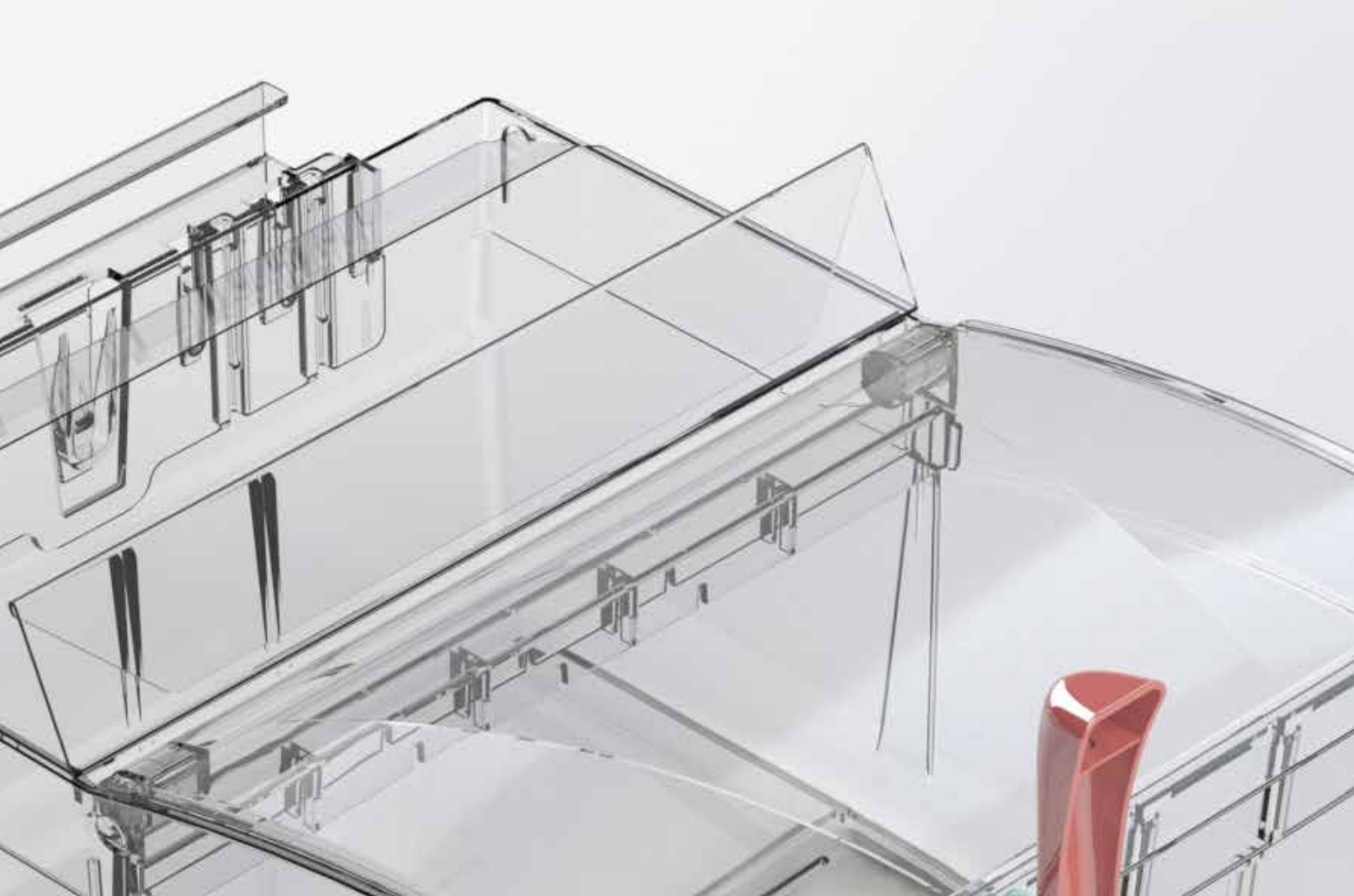

Akriform is the developer and manufacturer of **Pribox® Scoop Bin**, the **Quickbox Scoop Bin** and the **TurnOflex® Gravity Bin**.

Our goal is to offer complete solutions for Pick and Mix products to our worldwide clients through innovative technology. Akriform has produced Pick and Mix solutions for over 30 years and develops and produces new solutions with improvements for both the store and the end consumer. Many solutions are patented and protected.

Akriform is a leading manufacturer of acrylic, Plexiglas®, products. Our team of designers and engineers develop products and solutions for retail, medical, entertainment, governmental and industrial industries - we believe in the possibilities of plastic.

Akriform's headquarter and manufacturing plant is located in Stockholm, Sweden.

AKRIFORM

Bergkällavägen 38,
SE-192 79 Sollentuna, Sweden
Telephone: +46 (0)8 625 99 00
E-mail: info@akriform.se
www.akriform.com